

APPLICATION:

PRODUCT NAME:

PRE-RINSE SPRING STYLE
8" C/C DECK MOUNT

JOB NAME:

_____ SPECIAL CONFIGURATION
CHECK BASE MODEL AND OPTIONS

QUANTITY:

ITEM NO.

MODEL:

- 2310 ULTRA SPRAY VALVE, NO WALL BRACKET
- 2310-WB ULTRA SPRAY VALVE, WALL BRACKET

OPTIONS OR MODIFICATIONS:

- SUPPLY LINES (24" OR 36") CIRCLE LENGTH
- ADD-ON FAUCET (6", 8", 10", 12", 14", 16") CIRCLE
- IN-LINE DUAL CHECK VALVE
- BRUSH
- VANDAL RESISTANT KIT
- HANDLES (CROSS OR WRIST) CIRCLE STYLE
- OTHER _____

FEATURES

CONTROL VALVE

- * 8" C/C DECK MOUNT
- * INTERNAL SPRING LOADED CHECK VALVES
- * SWIVELLING SEAT DISKS
- * HOT SIDE STEM - RIGHT HAND
- * COLD SIDE STEM - LEFT HAND
- * STAINLESS STEEL SEATS
- * STAINLESS STEEL SEAT SCREWS
- * STAINLESS STEEL HANDLE SCREWS
- * 1/2" SLIP JOINT KIT

HOSE

- * 36" LENGTH
- * STAINLESS STEEL END FITTINGS
- * STAINLESS STEEL EXTERNAL JACKET
- * 3 PLY FIBER REINFORCED INTERNAL RUBBER HOSE
- * REPAIRABLE IN FIELD WITH SIMPLE TOOLS

ULTRA SPRAY VALVE

- * LOWEST ENERGY USER - 1.15 GPM @ 60 PSI
- * CLEANS FASTER - TEST PROVEN
- * ENGINEERED TO LAST - NO 'O' RINGS TO LEAK
- * INTERCHANGEABLE - FITS ALL BRANDS

WALL BRACKET

- * ADJUSTS FROM 2" TO 12"

SYSTEM LIMITS

- * TEMP: 40°F MIN. TO 140°F MAX.
- * PRESSURE: 200 PSI MAX. STATIC

SHIPPING WEIGHT

- * 12.0 LBS

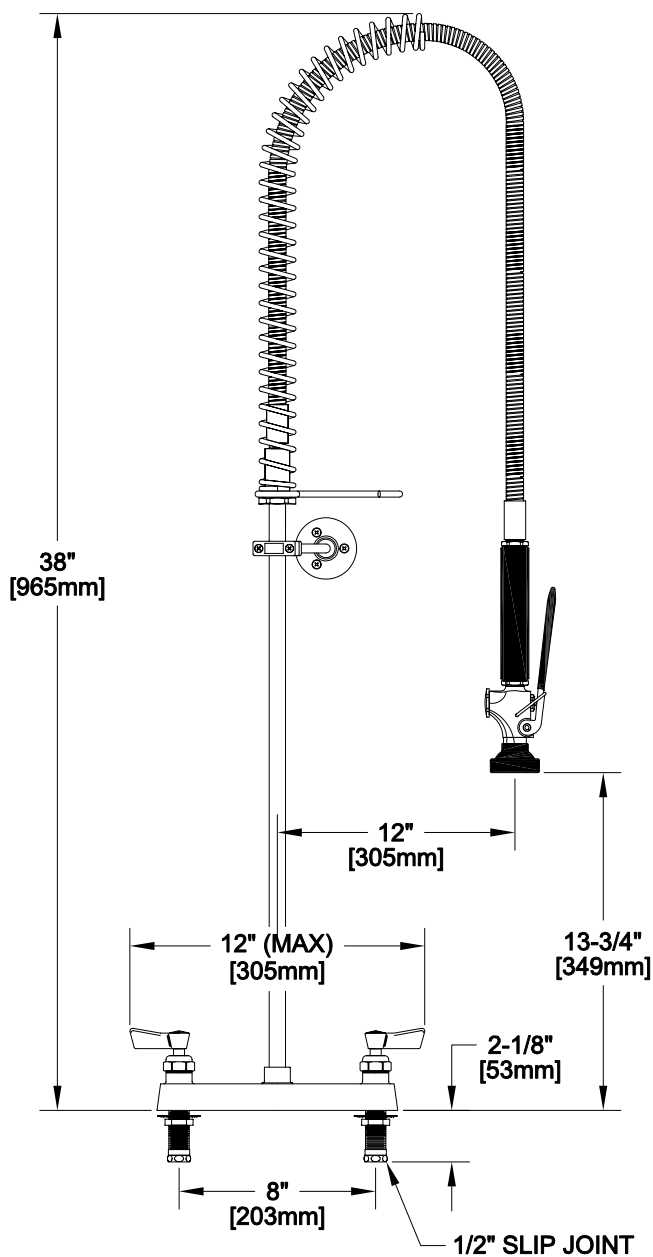

FOOTPRINT:

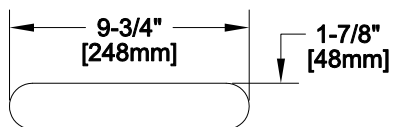

ROUGH-IN:

